



Free 8' x 20' Chicken Coop Plan

Up to 12 chickens



Compare Free vs. Premium plan

	Free plan	Premium edition
Pages	22	38
Illustrations for Each Step	✓	✓
Print Ready	✓	✓
Step By Step Instructions	✓	✓
Full Materials and Cuttings List	✗	✓
Additional Illustrations	✗	✓
Additional Blueprints	✗	✓
Tools List	✗	✓
Fastening Elements List	✗	✓
Technical Support	✗	✓

[TRY PREMIUM](#)

Size & Dimensions

front

∠10/12

∠3/12

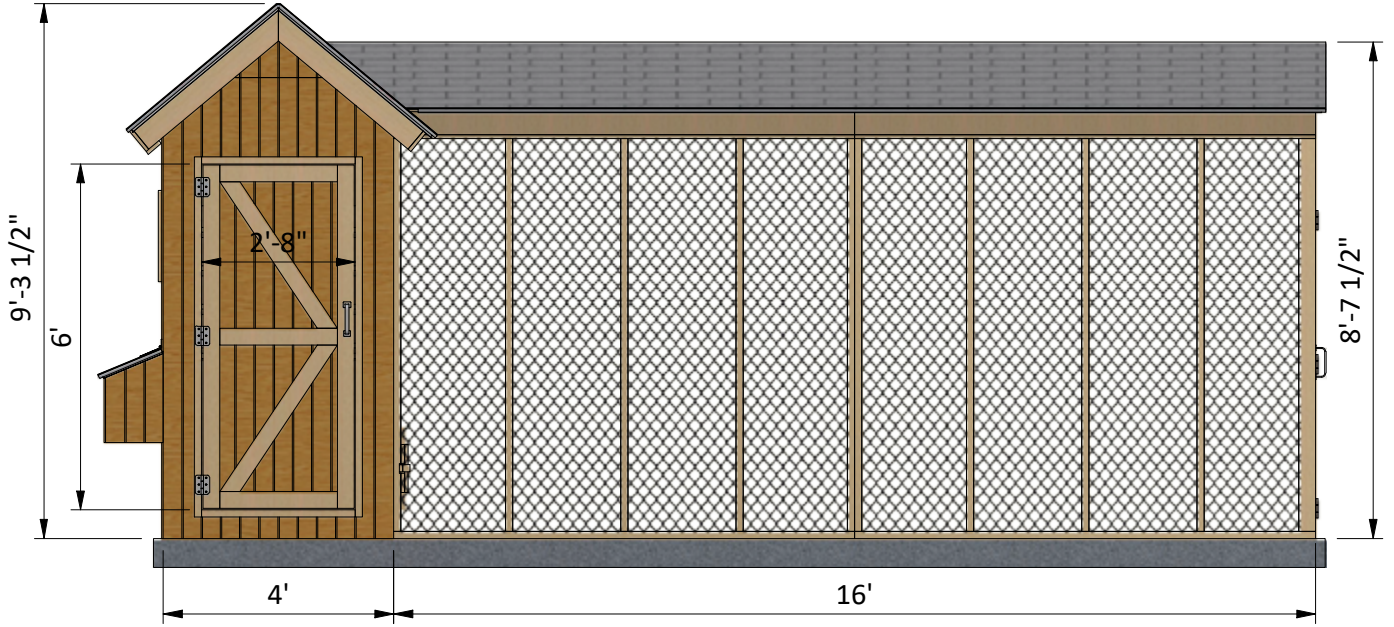

back

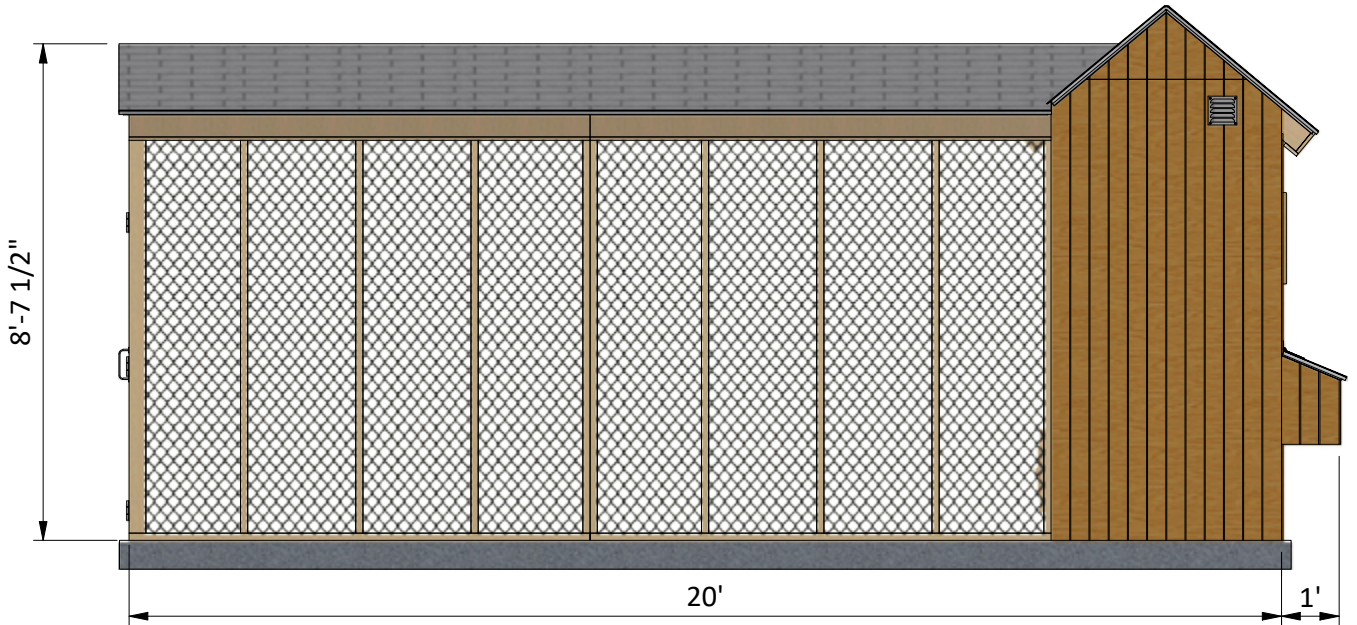

left

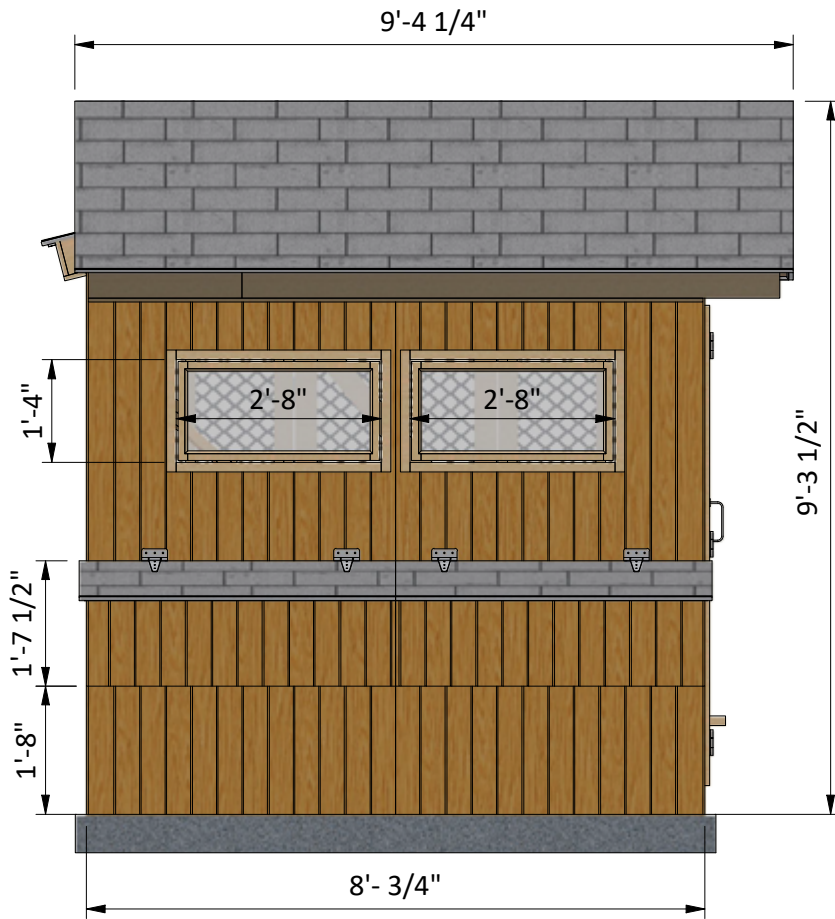

right

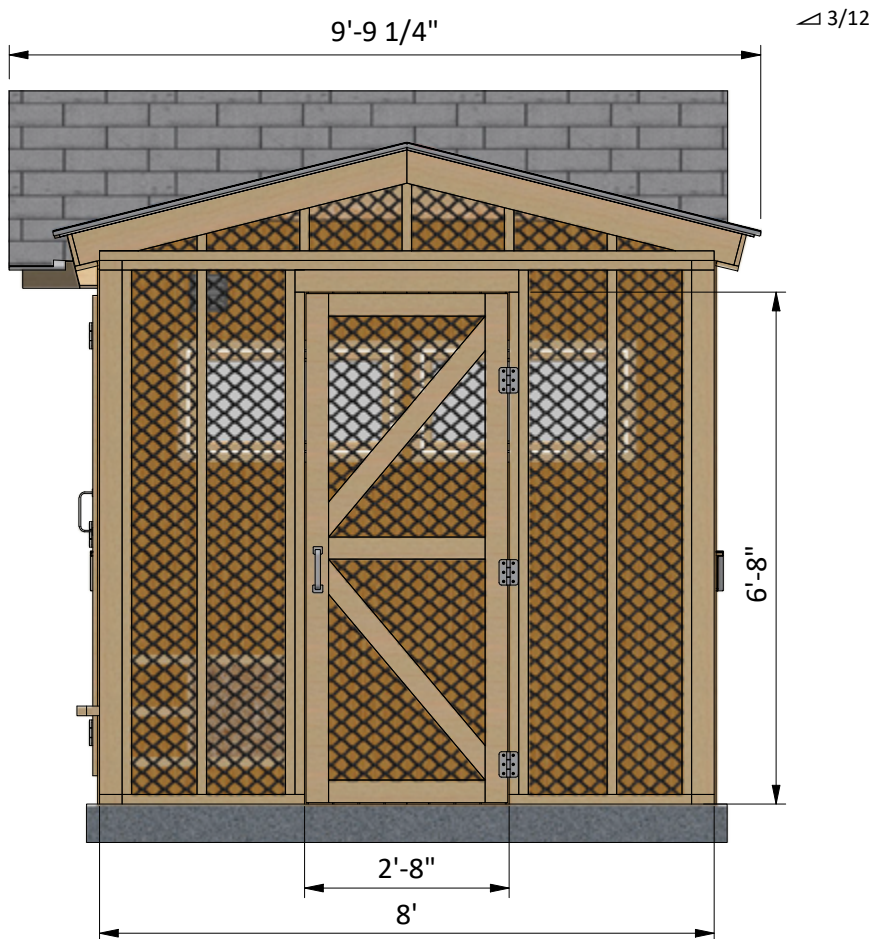

Interior view

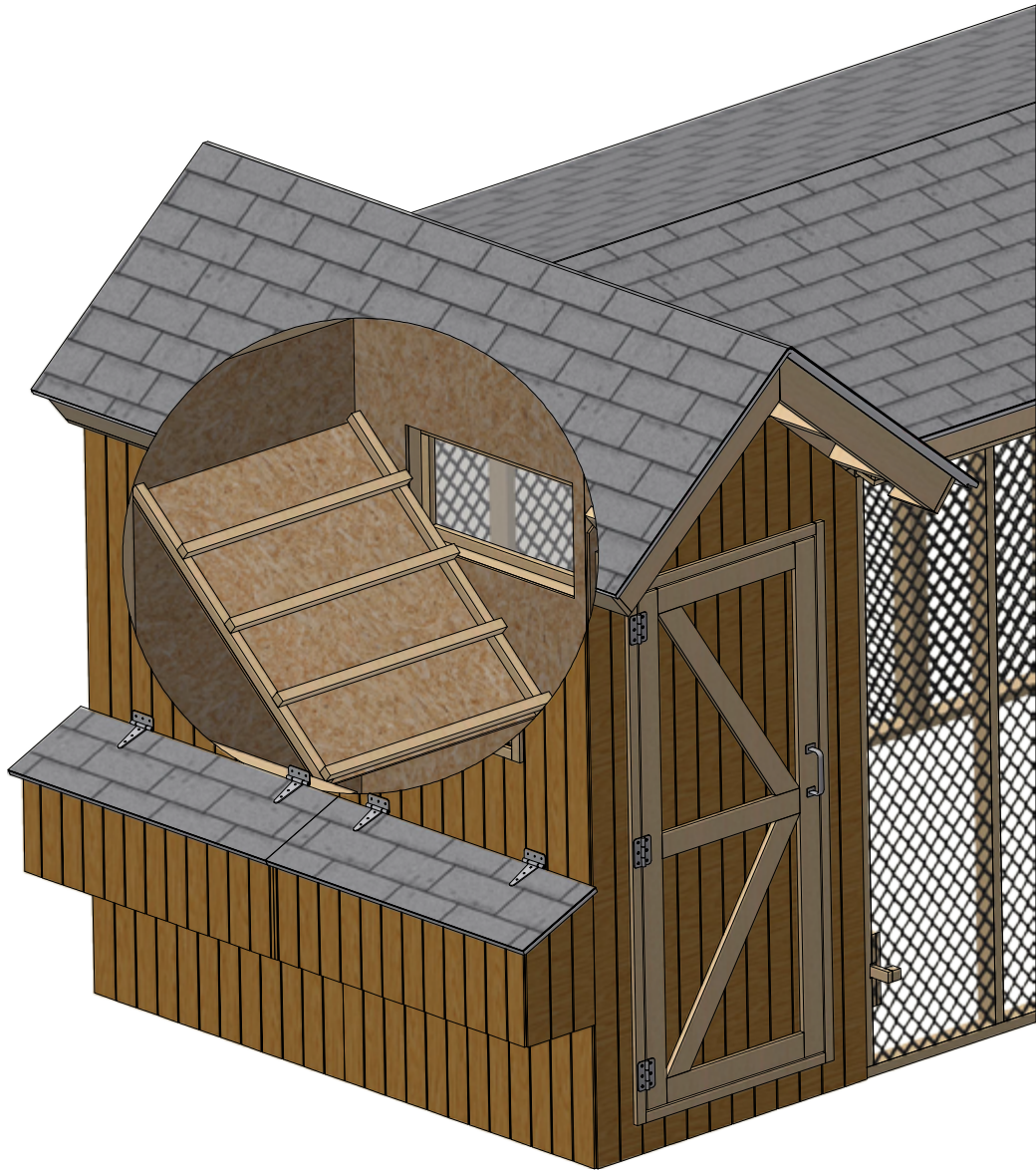

STEP 1

Framing the Coop's Floor

1.1 Assemble the frame using 2x6 lumber. You will need to prepare beams in necessary quantity according to the cutting list below.

1.2 Secure the beams with 3" wood screws.

1.3 Using a speed square or carpenter's square, check the corners to make sure they are 90°.

Pos	Description	Material	Dimension	Qty
A	Rim joist	2x6	8'	2
B	Joist	2x6	3'-9"	7

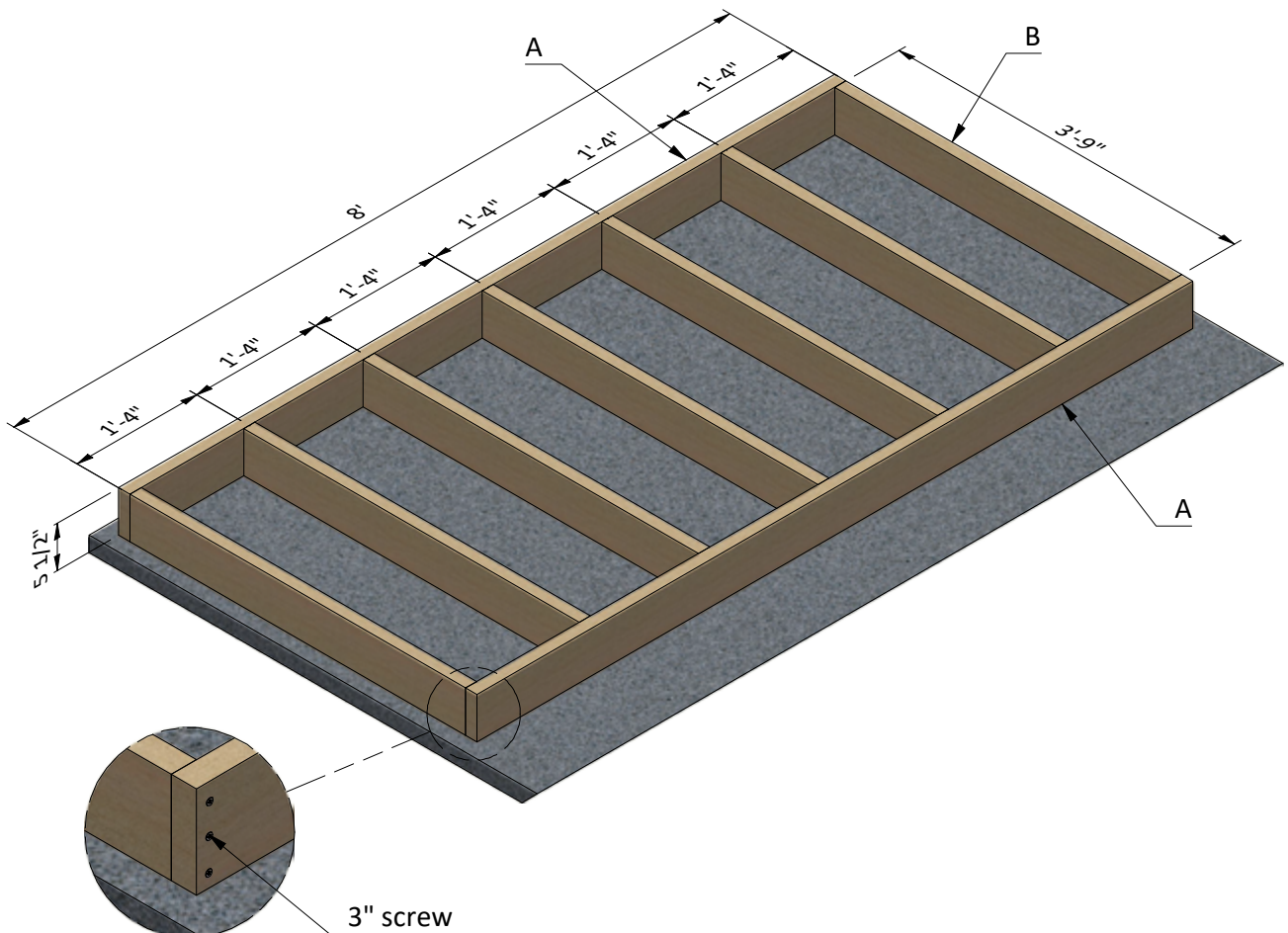

STEP 2

Install the Floor Sheathing

2.1 Prepare the 1/2" OSB for the floor sheathing according to the drawing. You will need one 4' x 8' sheet.

2.2 Secure the OSB with 2" wood screws.

Pos	Description	Material	Dimension	Qty
A	Floor sheathing	1/2" OSB	4' x 8'	1

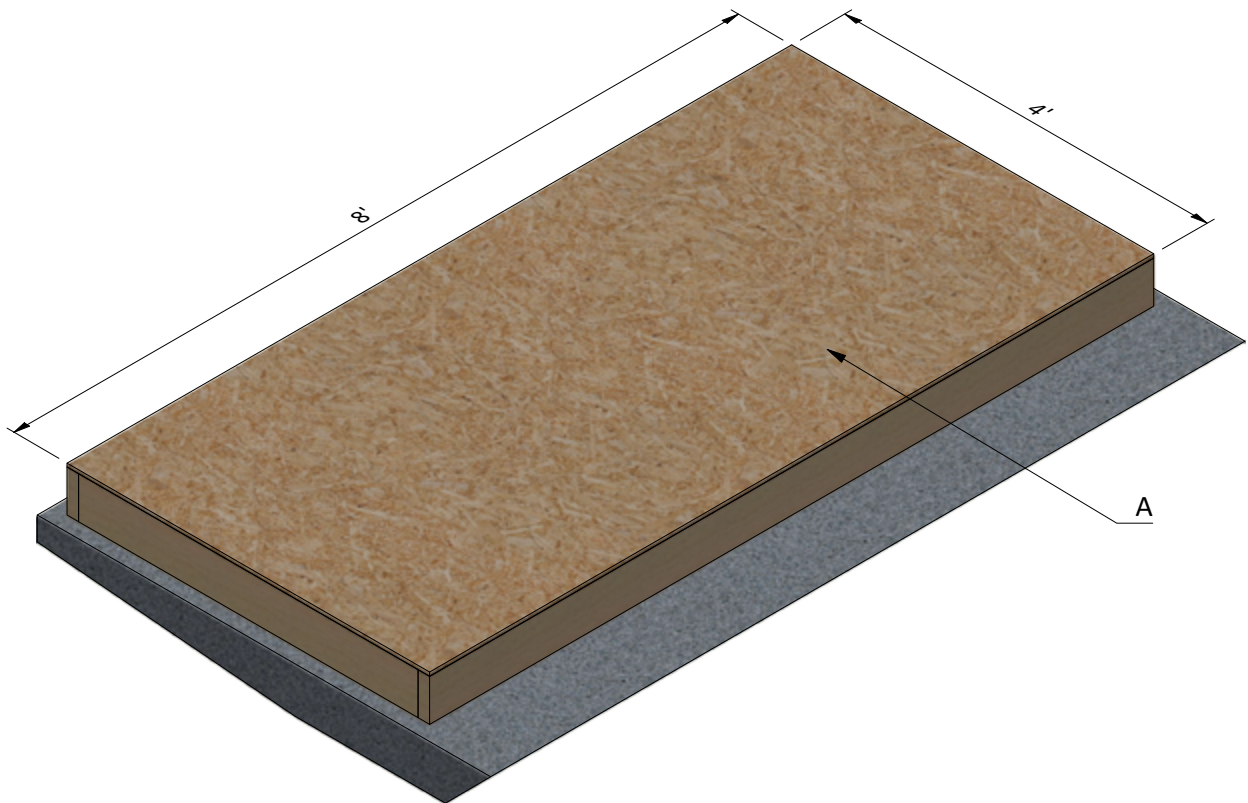

STEP 3

Assemble the Coop's Front Wall Frame

3.1 Using 2x4, 2x6 lumber, assemble the frame using the drawing below as a reference. You will need to prepare beams in necessary quantity according to the cutting list below.

3.2 Secure the beams with 3" wood screws.

Pos	Description	Material	Dimension	Qty
A	Stud	2x4	6'-4"	4
B	Stud	2x4	5'-10 1/2"	2
C	Top beam	2x4	4'	1
D	Bottom beam	2x4	8"	2
E	Door header	2x6	2'-11"	2

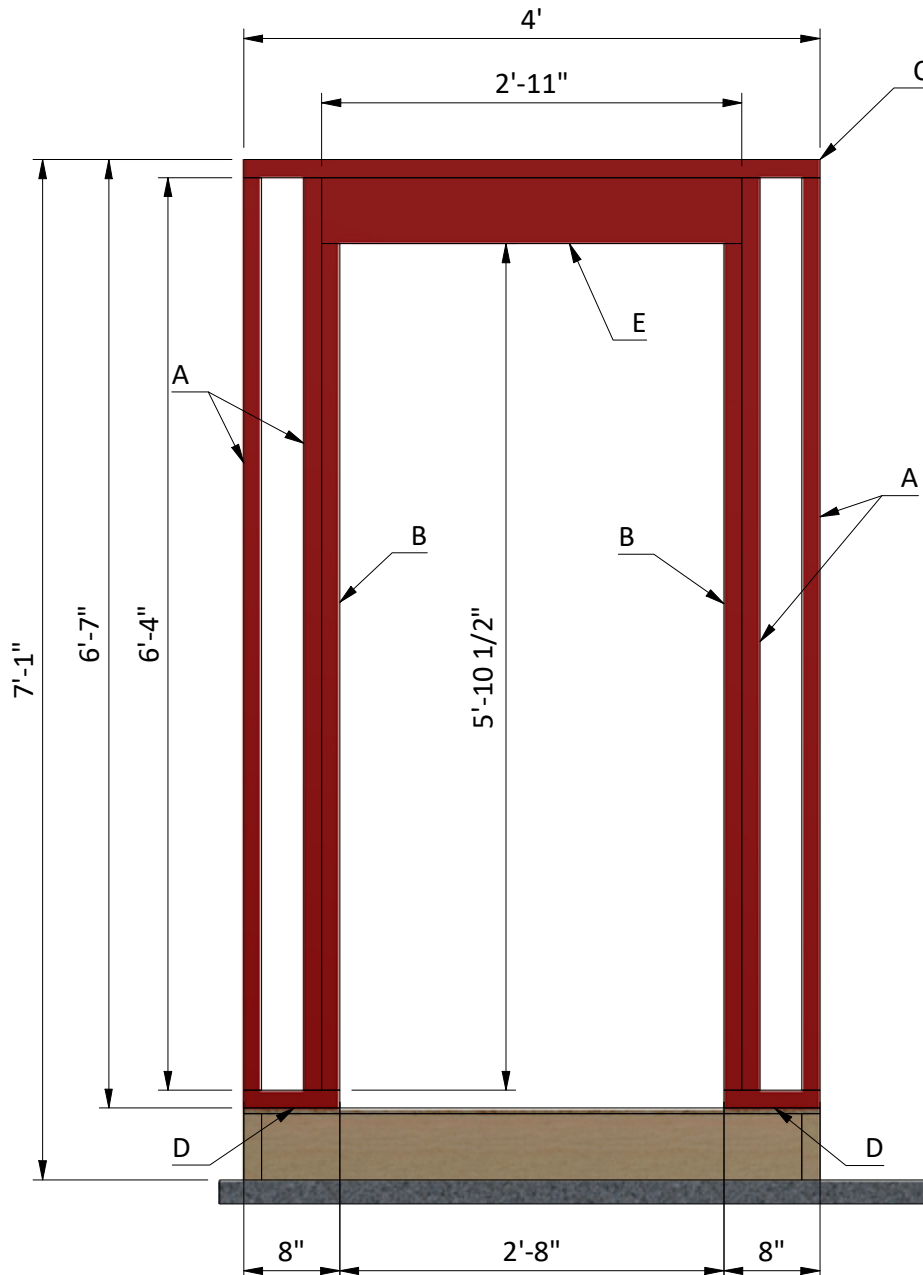

STEP 4

Assemble the Coop's Back Wall Frame

4.1 Using 2x4 lumber, assemble the frame using the drawing below as a reference. You will need to prepare beams in necessary quantity according to the cutting list below.

4.2 Secure the beams with 3" wood screws.

4.3 Using a speed square or carpenter's square, check the corners to make sure they are 90°.

Pos	Description	Material	Dimension	Qty
A	Stud	2x4	6'-4"	4
B	Top/Bottom beam	2x4	4'	2

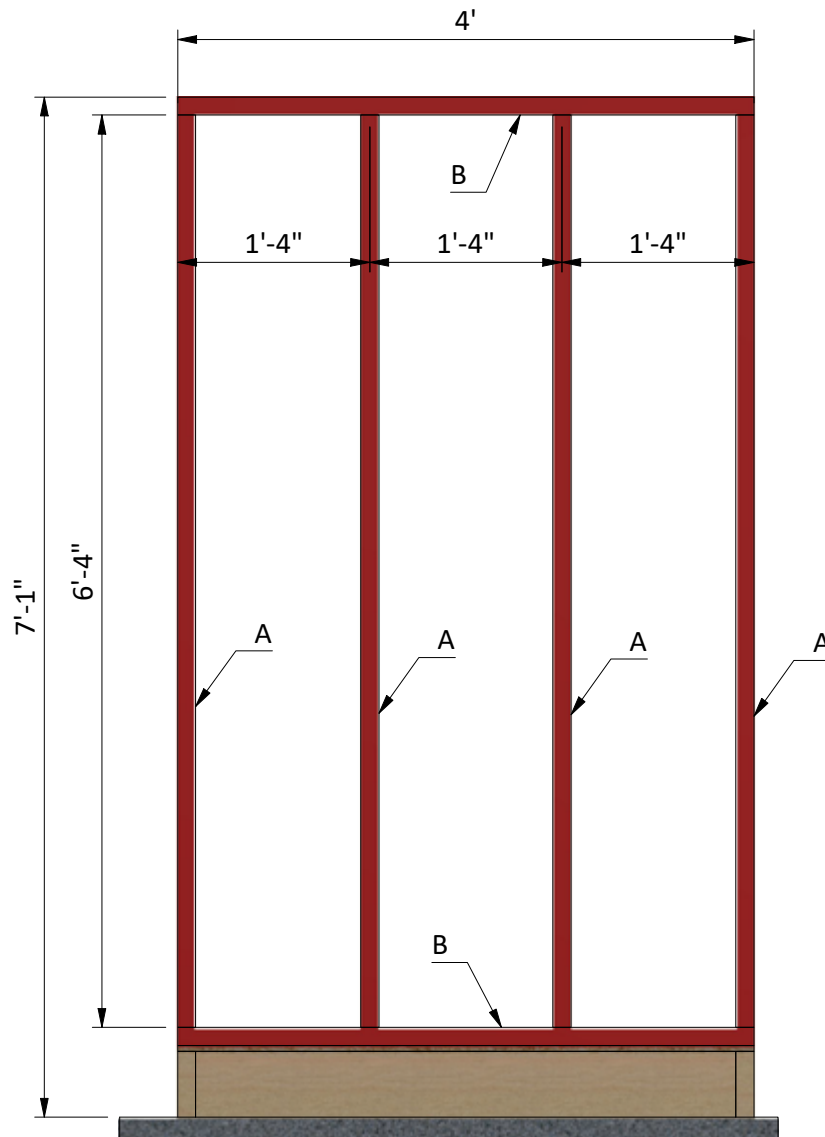

STEP 5

Assemble Left Wall Frame

5.1 Using 2x4 and 2x6 lumber, construct wall frame using the drawing below as a reference. You will need to prepare beams according to the cutting list below.

5.2 Connect the beams with 3" wood screws.

5.3 Using a speed square or carpenter's square, check the corners to make sure they are 90°.

Pos	Description	Material	Dimension	Qty
A	Top/Bottom beam	2x4	7'-5"	2
B	Stud	2x4	6'-4"	3
C	Stud	2x4	3'-8 1/2"	2
D	Stud	2x4	2'-8"	4
E	Stud	2x4	7"	6
F	Stud	2x4	1'-2 1/2"	2
G	Stud	2x4	1'-3 1/2"	6
H	Stud	2x4	1'-1"	4
I	Rouge sill	2x4	2'-8"	2
J	Girt	2x4	3'-6 1/4"	4
K	Door header	2x6	2'-11"	4

STEP 7

Assemble Right Wall Frame

7.1 Using 2x4 and 2x6 lumber, construct wall frame using the drawing below as a reference. You will need to prepare beams according to the cutting list below.

7.2 Connect the beams with 3" wood screws.

7.3 Using a speed square or carpenter's square, check the corners to make sure they are 90°.

Pos	Description	Material	Dimension	Qty
A	Top/Bottom beam	2x4	7'-5"	2
B	Stud	2x4	6'-4"	5
C	Stud	2x4	5'-3 1/2"	4
D	Stud	2x4	3'-10"	6
E	Stud	2x4	7"	6
F	Rough sill	2x4	2'-8"	2
G	Chicken door header	2x4	1'-1 3/4"	1
H	Door header	2x6	2'-11"	4

STEP 7

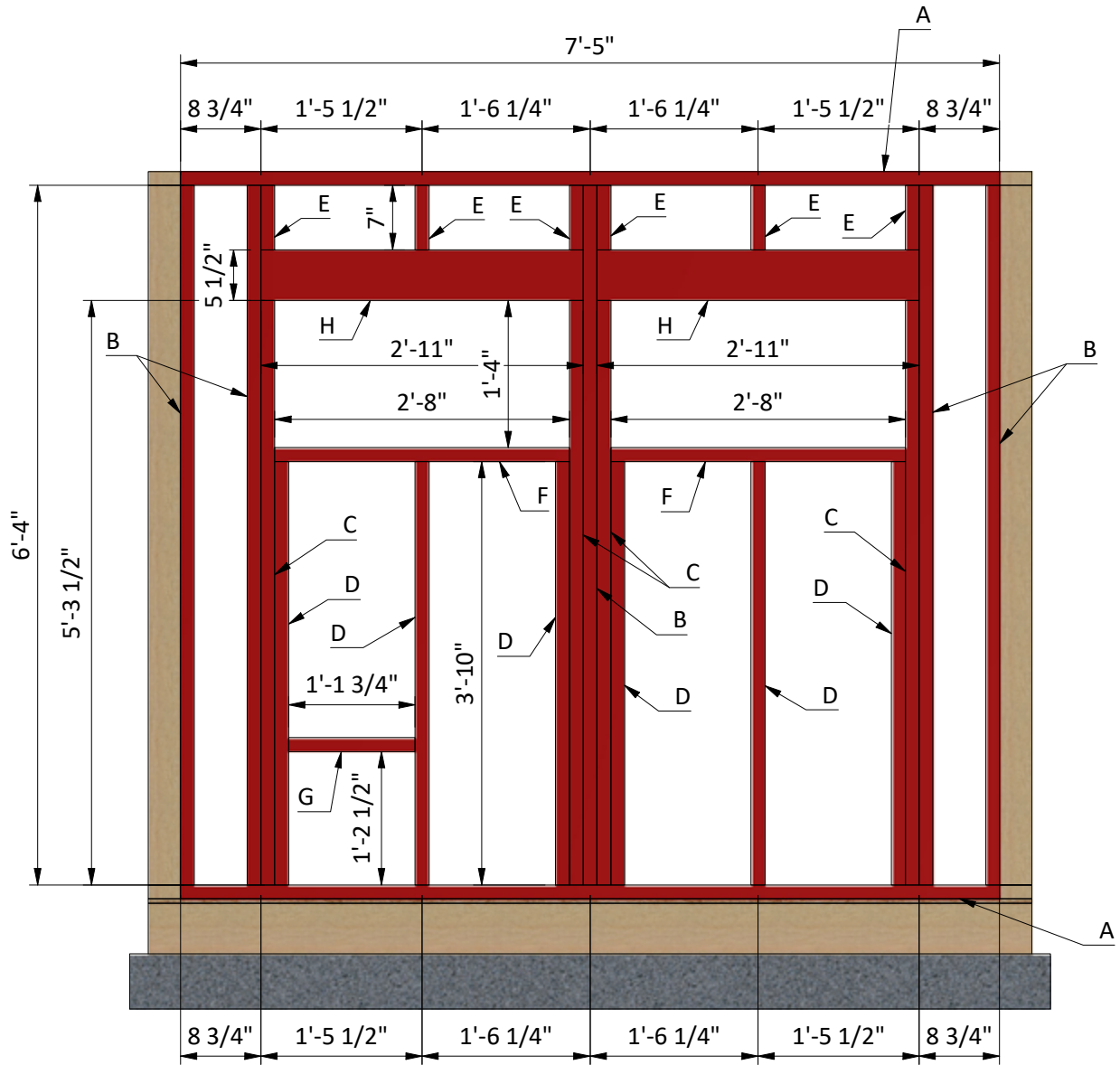

STEP 8

Assemble the Coop's Roof Frame

8.1 Using 2x4 and 2x6 lumber, prepare ten rafters, four ridge boards and three collar ties according to the drawing and cutting list below. Provide bird's mouth cuttings for the rafters and edge cuttings for the collar ties.

8.2 Connect the beams with 3" and 5" wood screws.

Pos	Description	Material	Dimension	Qty
A	Rafters	2x6	3'-3 3/4"	5
B	Rafters	2x6	2'-10"	5
C	Ridge board	2x6	1'-9 3/4"	2
D	Ridge board	2x6	1'-10 1/2"	2
E	Collar tie	2x4	3'-6 3/4"	3

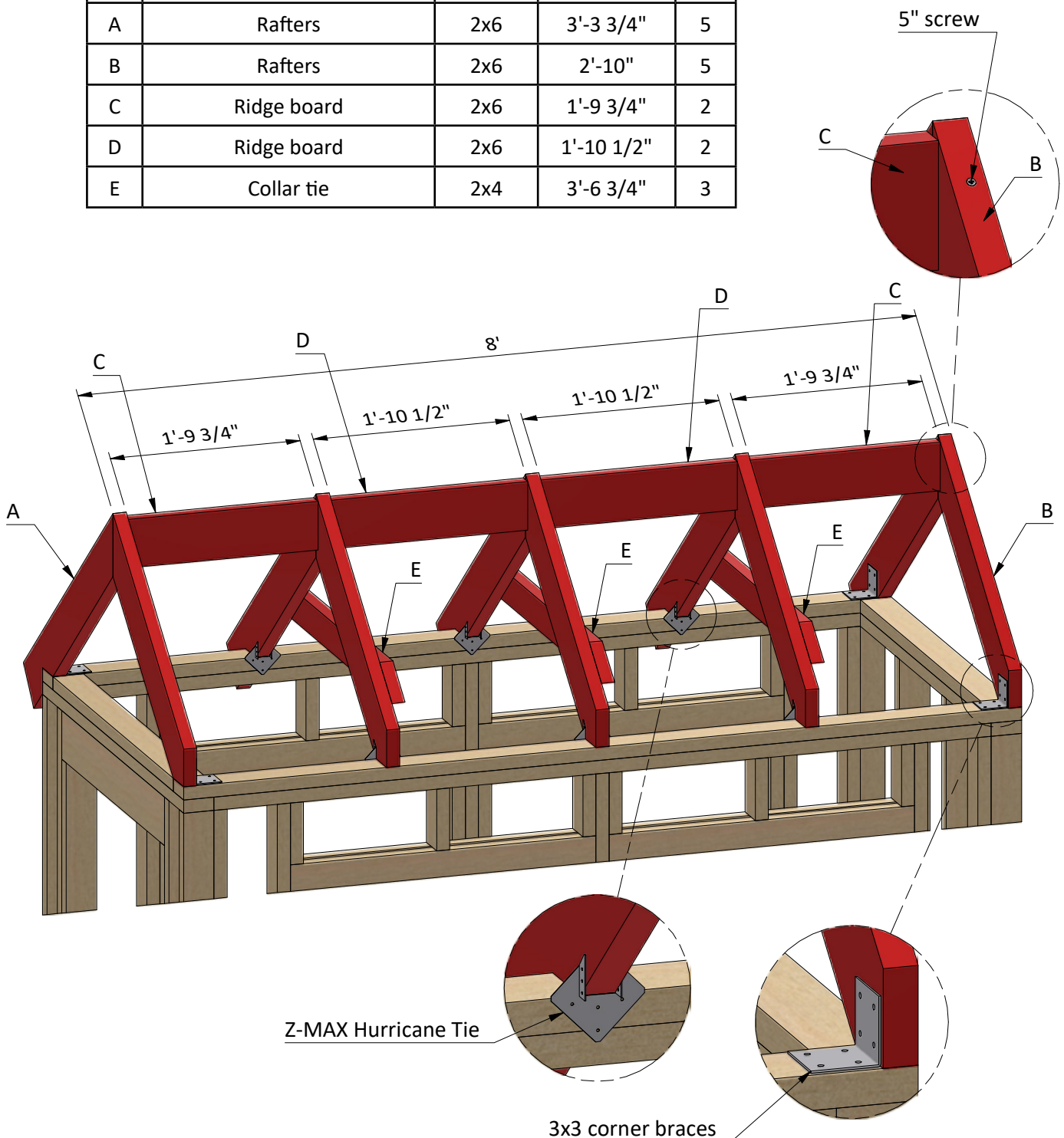

STEP 9

Nesting Box Frame Assembly

9.1 Cut sheet of 1/2" OSB for the nesting box floor sheathing and inner partition using the drawing below as a guide. You will need to prepare sheets for the floor and partitions according to the cutting list below.

9.2 Secure the OSB with 2" wood screws.

Pos	Description	Material	Dimension	Qty
A	Inner partitions	1/2" OSB	1'-1 1/2" x 1'-6 1/2"	6
B	Floor sheathing	1/2" OSB	1' x 4'	2

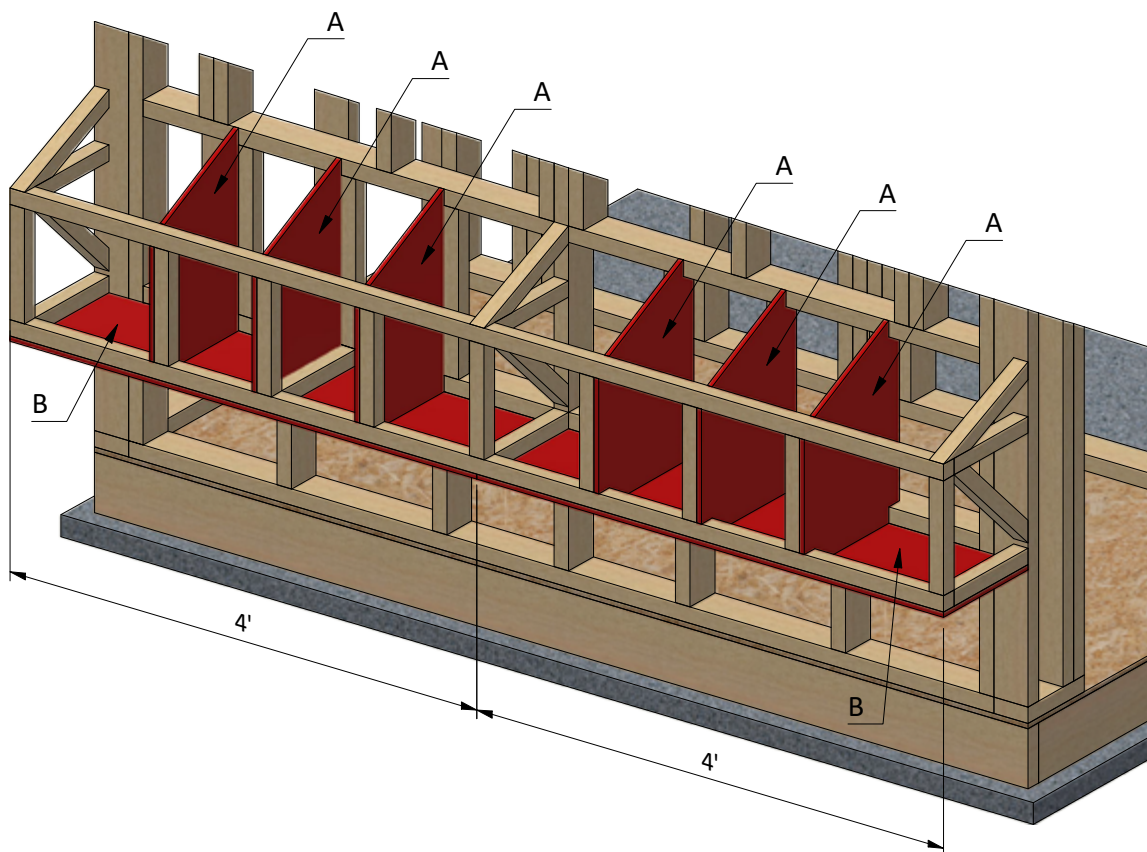

STEP 10

Assemble the Aviary Side Wall Frames

10.1 Using 2x4 lumber, assemble the frames using the drawing below as a reference. You will need to prepare beams in necessary quantity according to the cutting list below.

10.2 Secure the beams with 3" wood screws.

10.3 Using a speed square or carpenter's square, check the corners to make sure they are 90°.

Pos	Description	Material	Dimension	Qty
A	Top/Bottom beam	2x4	8'	8
B	Stud	2x4	6'-10"	18
C	Stud	4x4	6'-10"	2

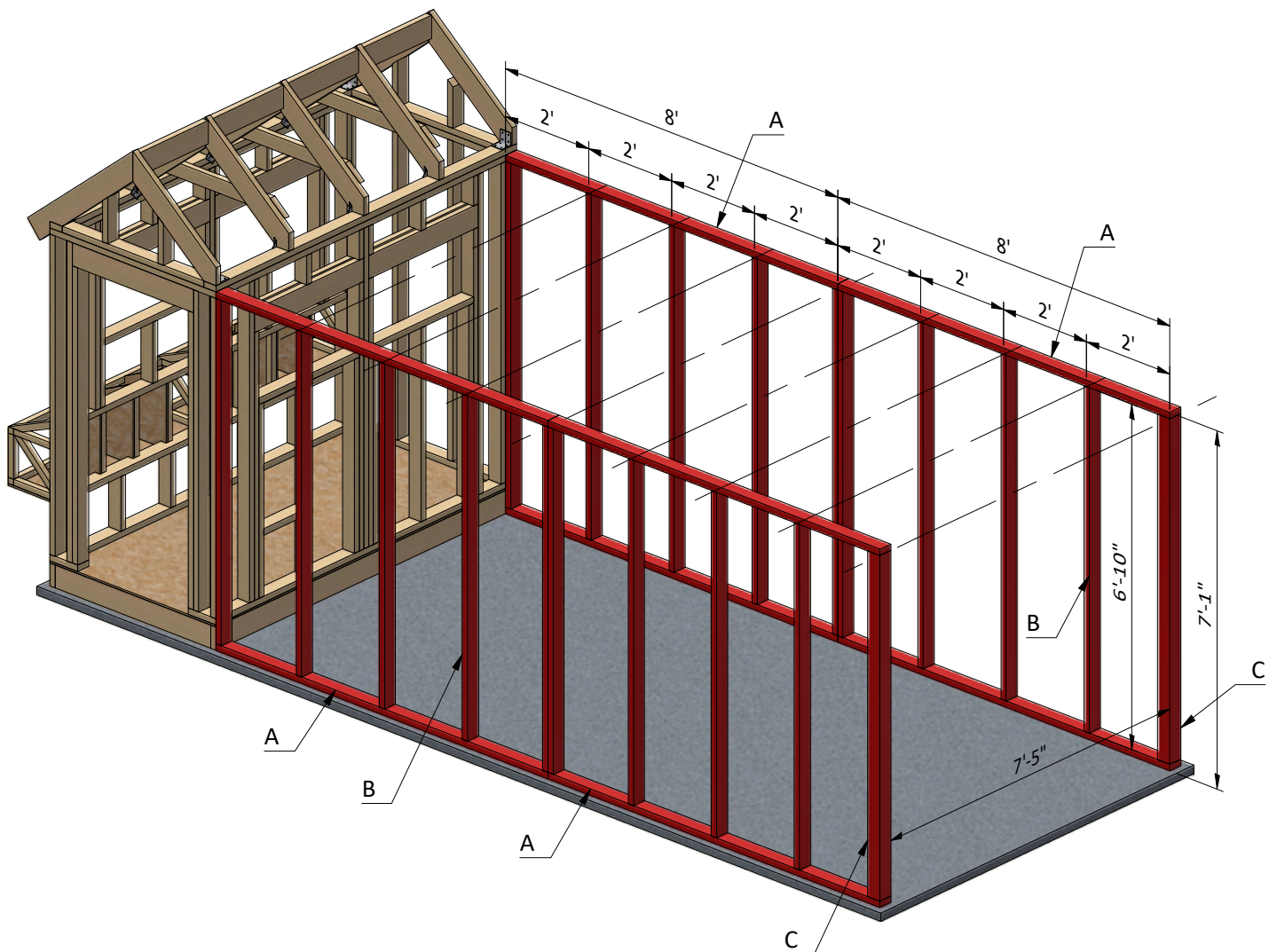

STEP 11

Assemble the Aviary Right Wall Frame

11.1 Using 2x4 lumber, assemble the frame using the drawing below as a reference. You will need to prepare beams in necessary quantity according to the cutting list below.

11.2 Secure the beams with 3" wood screws.

Pos	Description	Material	Dimension	Qty
A	Stud	2x4	6'-10"	6
B	Stud	2x4	6'-6 1/2"	2
C	Top beam	2x4	7'-5"	1
D	Bottom beam	2x4	2'-4 1/2"	2
E	Door header	2x4	2'-11"	2

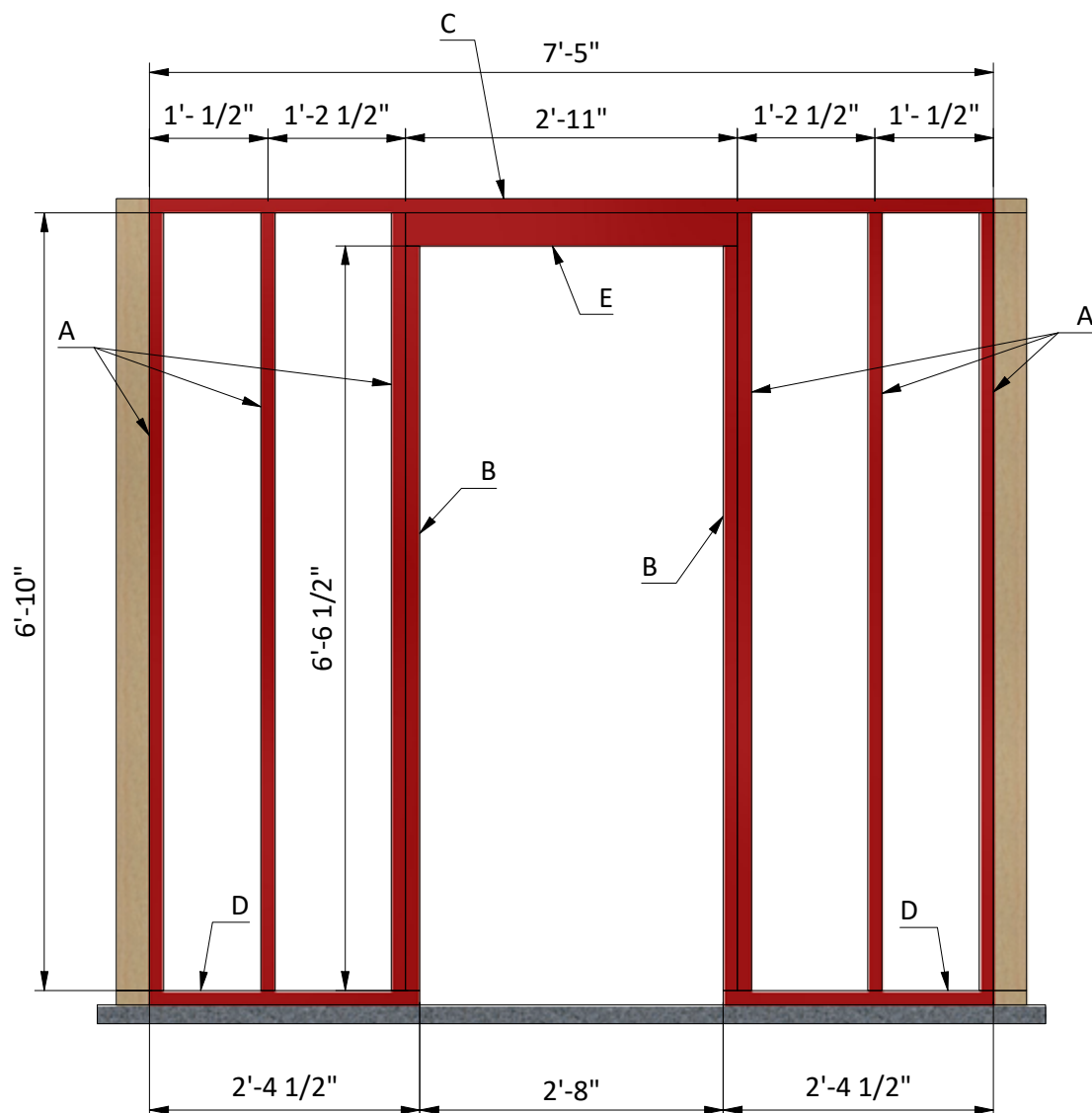

STEP 12

Assemble the Aviary Top Beams

12.1 Using 2x4 lumber, assemble the top beam layer using the drawing below as a reference. You will need to prepare beams in necessary quantity according to the cutting list below.

12.2 Secure the beams with 3" wood screws.

12.3 Using a speed square or carpenter's square, check the corners to make sure they are 90°.

Pos	Description	Material	Dimension	Qty
A	Top beam	2x4	8'	3
B	Top beam	2x4	4'	2
C	Top beam	2x4	3'-8 1/2"	2

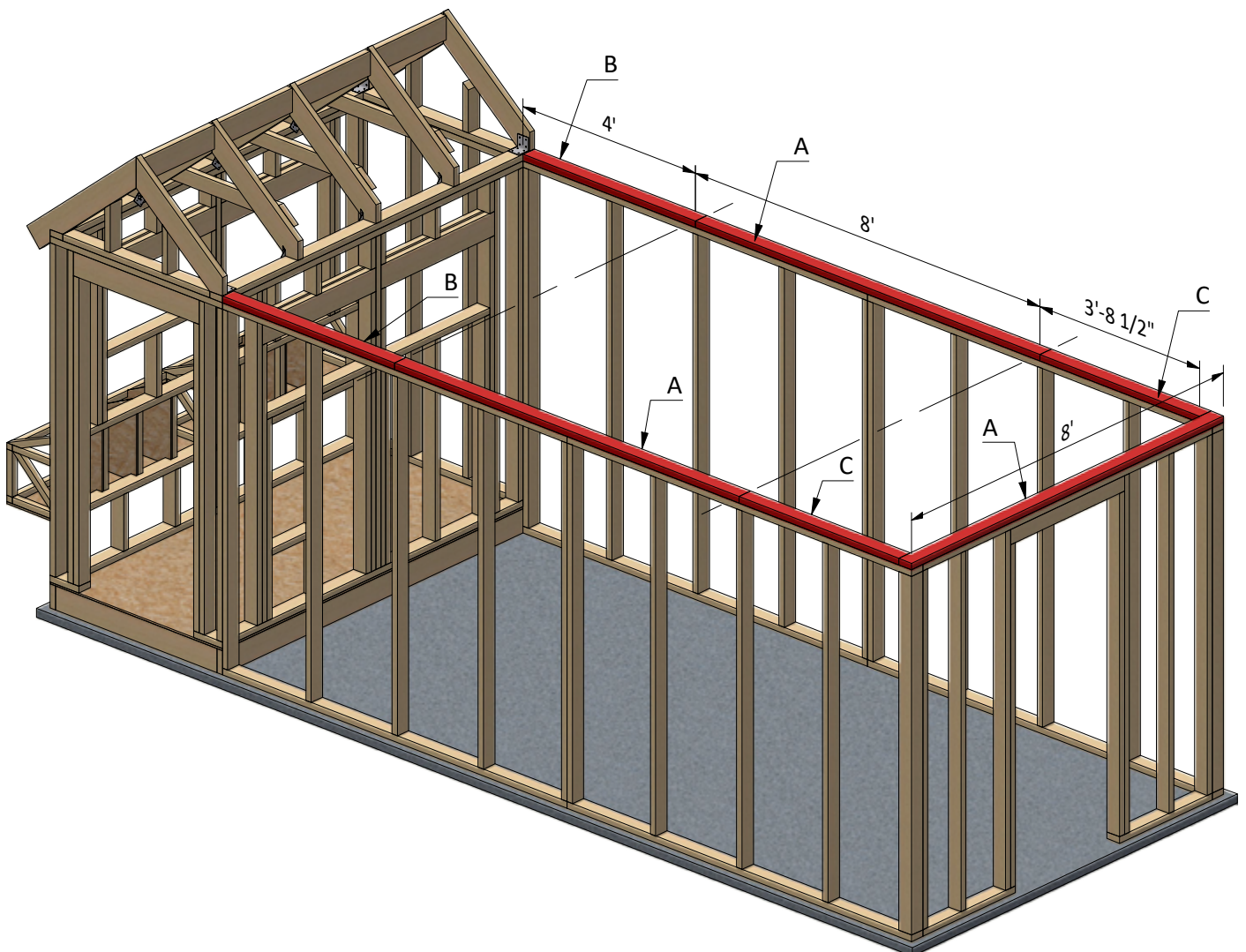

STEP 13

Assemble the Coop's Roof Frame

13.1 Using 2x4 and 2x6 lumber, prepare eighteen rafters, eight ridge boards and eight collar ties according to the drawing and cutting list below. Provide bird's mouth cuttings for the rafters and edge cuttings for the collar ties.

13.2 Connect the beams with 3" and 125mm wood screws.

Pos	Description	Material	Dimension	Qty
A	Rafters	2x6	4'-6"	18
B	Collar tie	2x4	6'	8
C	Ridge board	2x6	1'-9 3/4"	2
D	Ridge board	2x6	1'-10 1/2"	6

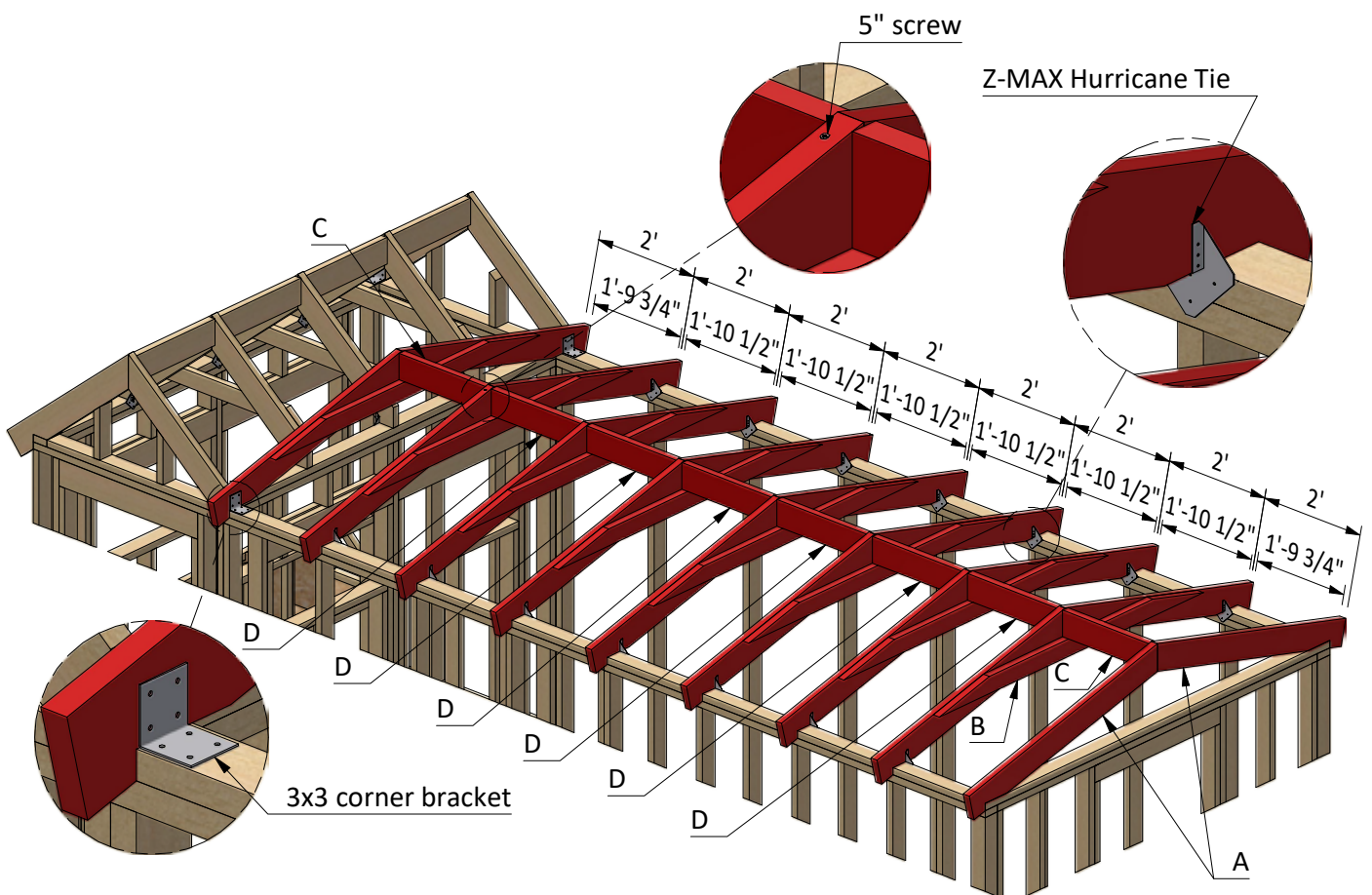

STEP 14

Assemble and Install Coop's Front Door

14.1 Build the door frame using 2x2 lumber. You will need two boards cut to 5'-11 1/2" that will be the vertical girts and two board cut to 2'-4 1/2" that will be the horizontal girts.

14.2 Prepare the 11/32" plywood siding panel for the outer sheathing and one OSB (1/2") sheet for the inner sheathing in 2'-7 1/2" x 5'-11 1/2" sizes according to the drawing.

14.3 Using 1x4 lumber, prepare trims and install with 2" wood screws to the frame. You will need to prepare boards in necessary quantity according to the cutting list below.

14.4 Cut sheet of 1" foam board for the door insulation. You will need to prepare one 2'-4 1/2" x 5'-8 1/2" sheet and insert it tightly.

14.5 Install three 4" door hinges using 1" wood screws. Finish the door installation by attaching 6" door pull.

Pos	Description	Material	Dimension	Qty
A	Door trim	1x4	5'-11 1/2"	2
B	Door trim	1x4	2'-1/2"	3
C	Door trim	1x4	3'-3"	2
D	Girt	2x2	5'-11 1/2"	2
E	Girt	2x2	2'- 4 1/2"	2
F	Door sheathing	11/32" plywood	2'-7 1/2" x 5'-11 1/2"	1
G	Insulation	1" foam board	2'-4 1/2" x 5'-8 1/2"	1
H	Inner door plane	1/2" OSB	2'-7 1/2" x 5'-11 1/2"	1

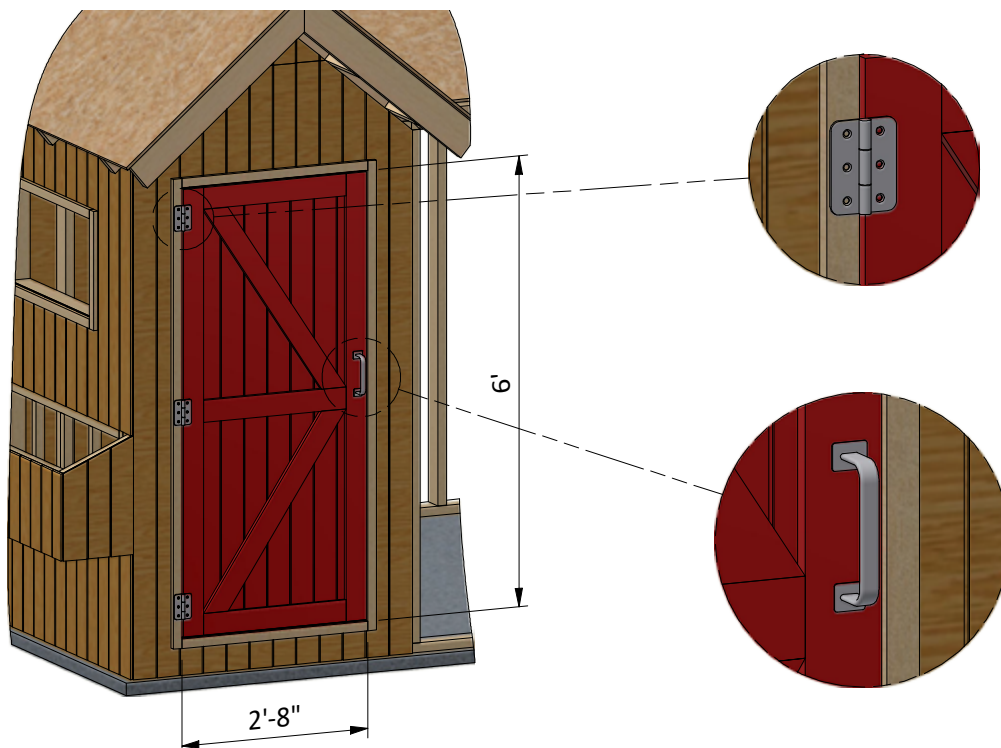

STEP 15

Window Installation for the Side Walls

You will need to assemble four windows

15.1 Using 2x2 lumber, assemble the outer frame for the window as shown in the drawing below. You will need two boards cut to 1'-3 1/2" that will be the vertical girts and two boards cut to 2'-7 1/2" that will be the horizontal girts. Cut the recesses in each beam for splicing connection and mill a recess for the glass.

15.2 Prepare and install glass into inner frame groove and fasten it by window beading from four sides. Use 1/2" galvanized nails.

15.3 Insert window into side wall openings and connect them with 3" wood screws to the wall beams.

Pos	Description	Material	Dimension	Qty
A	Vertical girts	2x2	1'-3 1/2"	8
B	Horizontal girts	2x2	2'-7 1/2"	8
C	Glass	1/8"	1'-1 1/4" x 2'-5 1/4"	4
D	Window beading			32ft

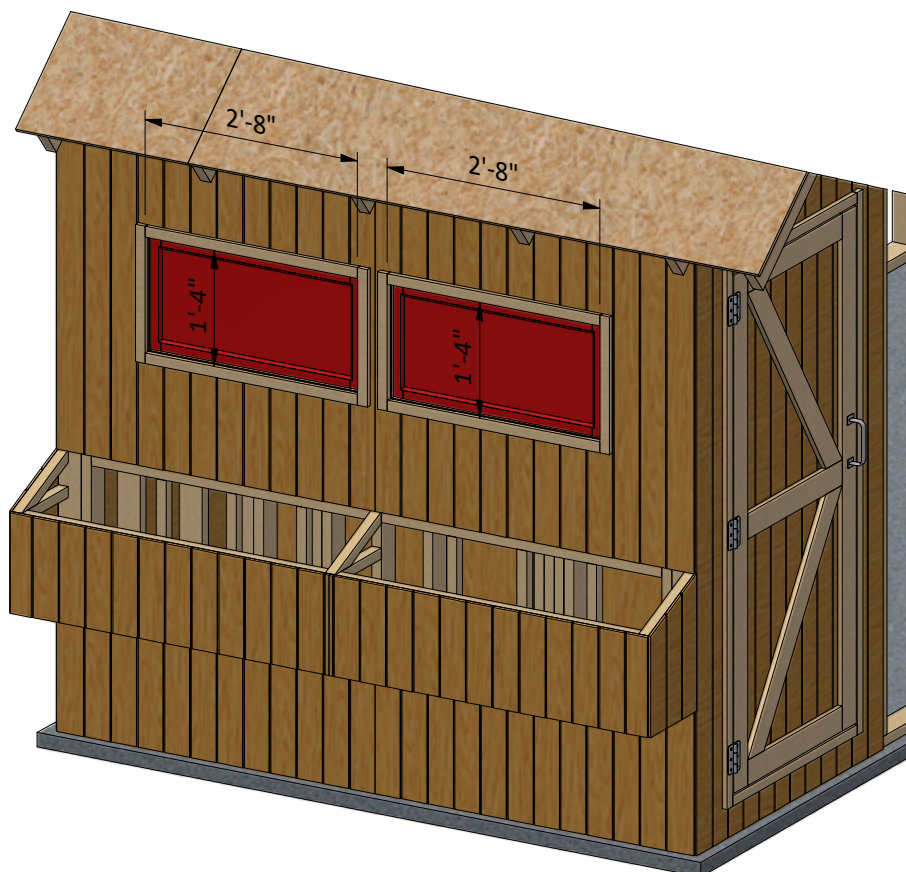

STEP 16

Coop's Roof Sheathing Installation

16.1 Prepare metal drip edge with 6" width. You will need 65' to cover all the perimeter.

16.2 Place the drip edge down, aligning it to the OSB edge. Use 2" nails to secure the first drip edge. When you place the next drip edge piece, it should overlap the first by an inch.

16.3 You will need 215 Sq Ft of building paper and asphalt shingle roofing.

16.4 Cover the OSB and drip edge with building paper. Try to install sheets with 1" overlapping. Use 2" nails to secure the sheets.

16.5 Install asphalt shingle roofing using an industrial stapler.

Pos	Description	Material	Dimension	Qty
A	Metal drip edge	6"	-	65'
B	Roof sheathing	Building paper	-	215 square ft
C	Roof sheathing	Asphalt shingle roofing	-	215 square ft

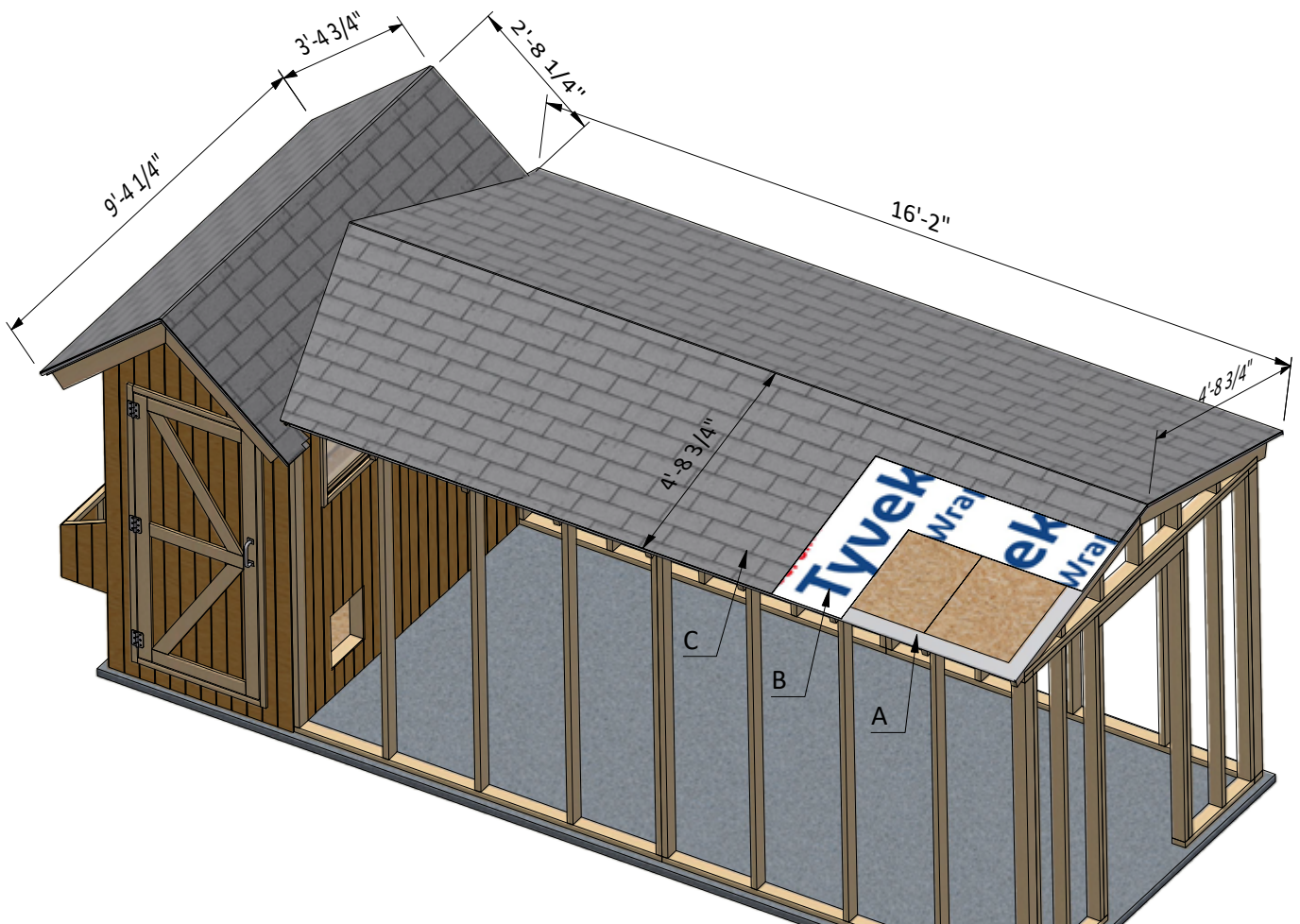

STEP 17

Installing the Nesting Box Lid

17.1 Cut sheet of 1/2" OSB for the lids using the drawing below as a guide. You will need two 1'-2 1/4" x 4'-1 1/2" sheets.

17.2 Prepare metal drip edge with 6" width. You will need 11' to cover all the outer edges.

17.3 Place the drip edge down, aligning it to the OSB edge. Use 1/2" nails to secure the first drip edge. When you place the next drip edge piece, it should overlap the first by an inch.

17.4 You will need 10 square ft of building paper and asphalt shingle roofing.

17.5 Cover the OSB and drip edge with building paper. Try to install sheets with 1" overlapping.

17.6 Install asphalt shingle roofing using an industrial stapler.

17.7 Finish the installation with four tee surface mount hinge 3"

Pos	Description	Material	Dimension	Qty
A	Lid sheathing	1/2" OSB	1'-2 1/4" x 4'-1 1/2"	2
B	Metal drip edge	6"	-	11'
C	Roof sheathing	Building paper	-	10 square ft
D	Roof sheathing	Asphalt shingle roofing	-	10 square ft

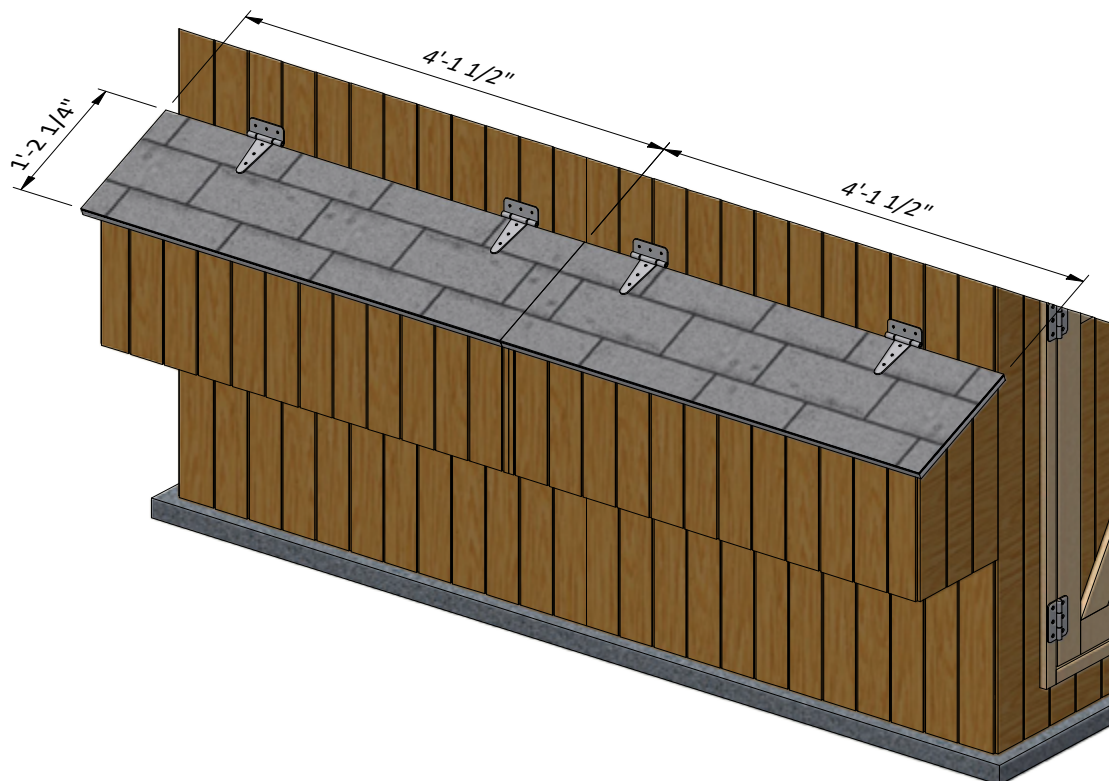

STEP 18

Assemble and Install Aviary Door

18.1 Build the door frame using 2x4 lumber.

You will need to prepare beams in necessary quantity according to the cutting list below.

18.2 Install three 4" door hinges using 1" wood screws.

Finish the door installation by attaching 6" door pull.

Pos	Description	Material	Dimension	Qty
A	Girt	2x4	6'-7 1/2"	2
B	Girt	2x4	2'-1/2"	3
C	Cross brace	2x4	3'-6 1/4"	2

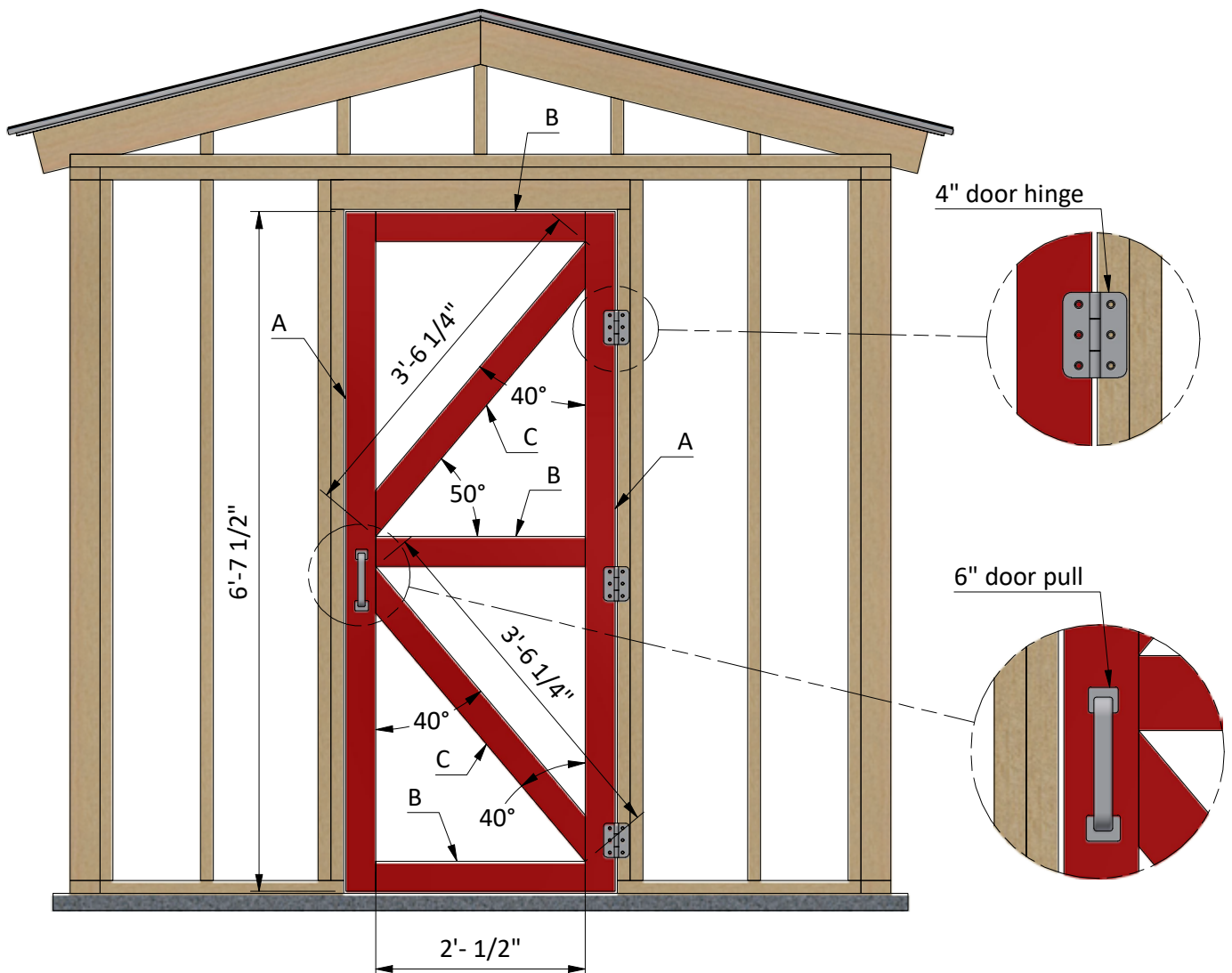

STEP 19

Mesh Wall Installation

19.1 Cover the walls with 1/4" wire mesh with the help of industrial stapler. You will need 260 sq ft.

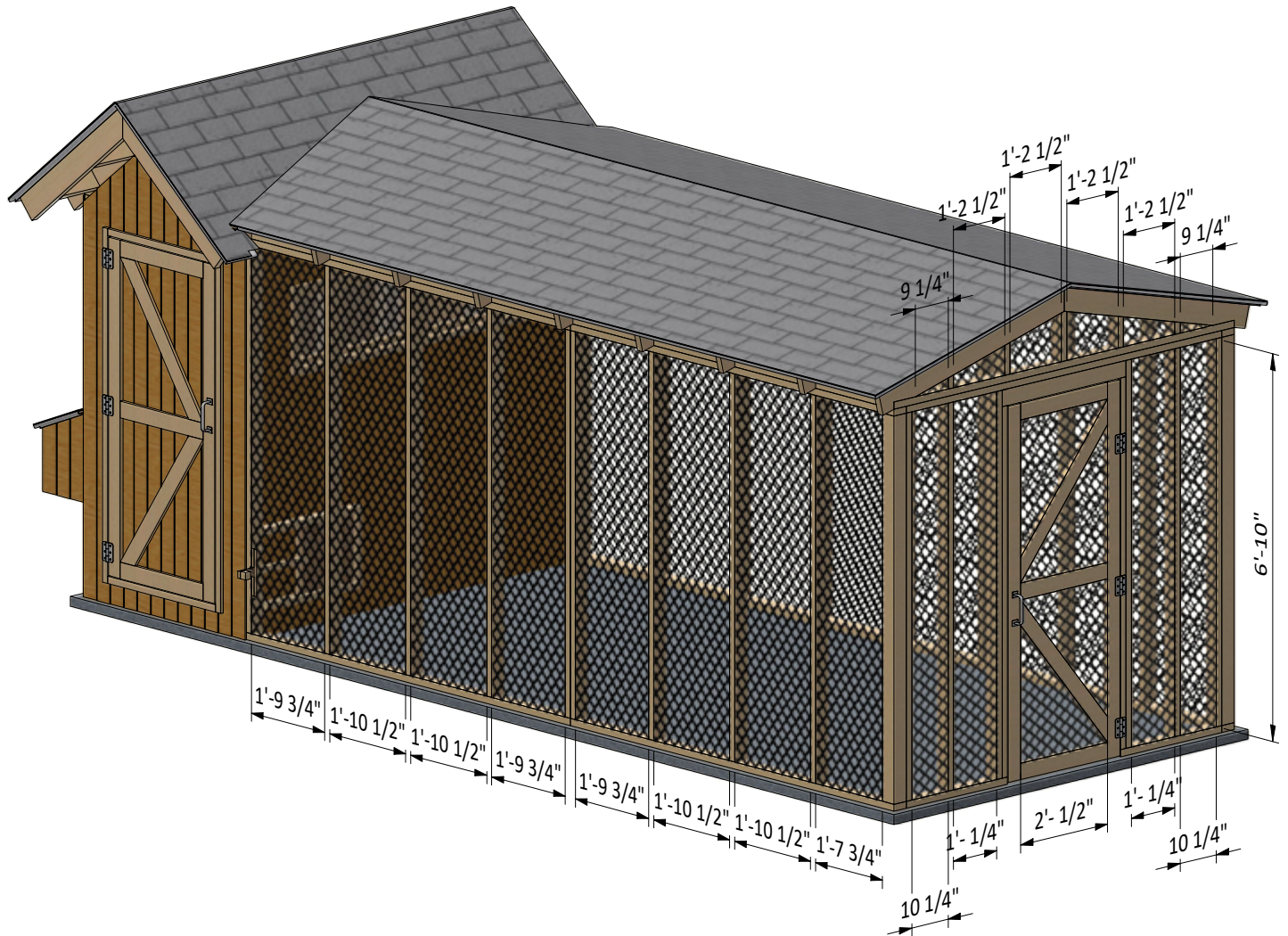

STEP 20

Install the Ventilation Louver

20.1 To install the ventilation louver, cut two 4 1/2" diameter holes in the top of the back and in the top of the right wall through the outer sheathing, insulation and inner sheathing.

20.2 Insert the 4" ventilation pipe to isolate the inner space between walls.

20.3 Fix the louvers to the outer and inner walls, completely overlaying the opening.

Pos	Description	Material	Dimension	Qty
A	Ventilation louver	26 Gauge galvanized steel	6" x 6"	4
B	Ventilation pipe	4" pipe	4 1/4"	2

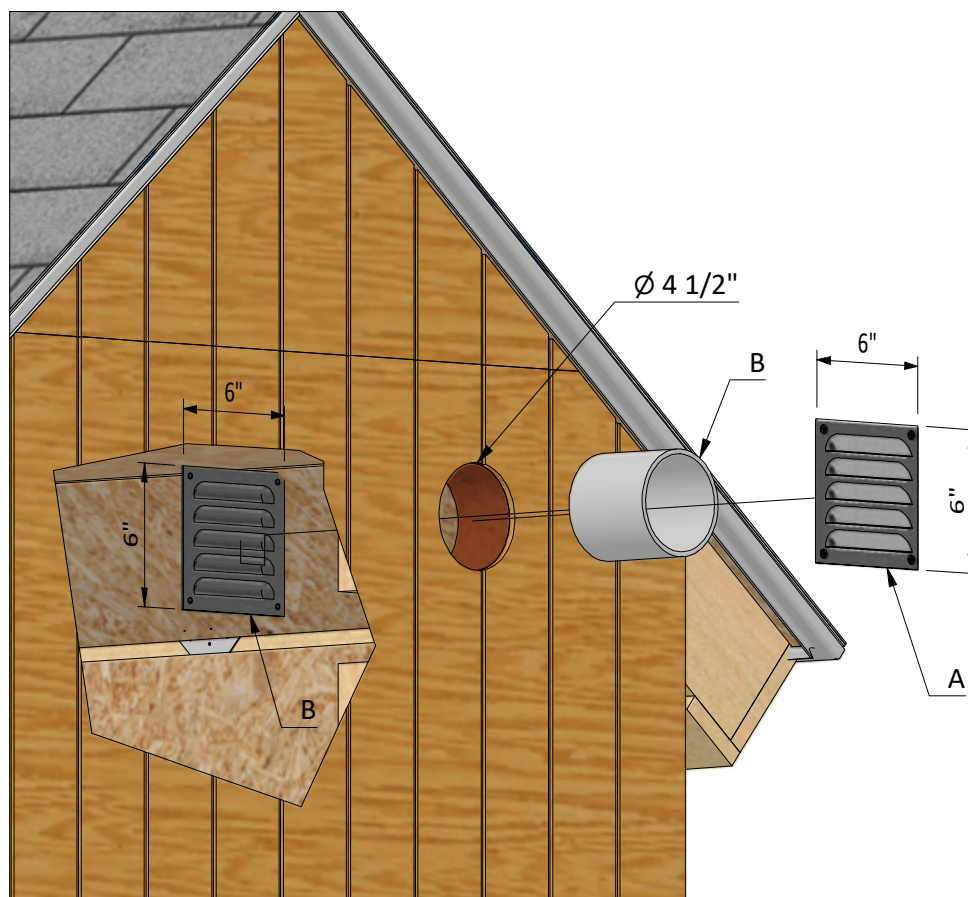

STEP 21

Assemble The Roost

21.1 Assemble the roost using 2x2 lumber.

You will need two boards cut to 4' and four boards cut to 3'-4".

21.2 Connect the beams with 2" wood screws.

21.1 Cut 1/2" OSB for the bottom plane and install it from below.

Pos	Description	Material	Dimension	Qty
A	Girt	2x2	2'-6"	2
B	Stair	2x2	3'-9 3/4"	2
C	Bottom plane	OSB (1/2")	3'-4" x 3'-11 1/2"	1

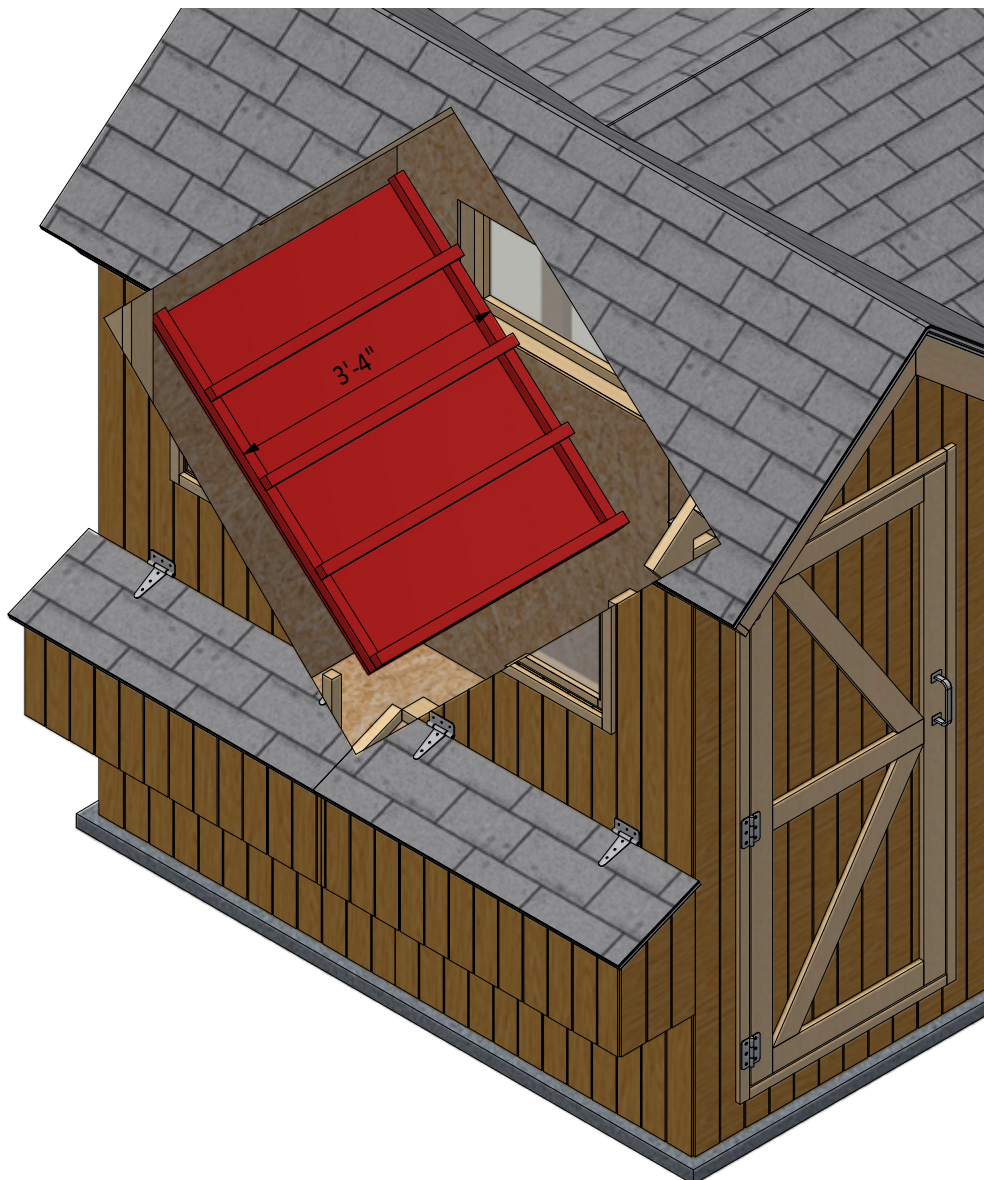

STEP 22

Final Touches

Now that your chicken coop is all done, you are ready to decorate it any way you want using your favorite paint, stain, or preservative.





Compare Free vs. Premium plan

	Free plan	Premium edition
Pages	22	38
Illustrations for Each Step	✓	✓
Print Ready	✓	✓
Step By Step Instructions	✓	✓
Full Materials and Cuttings List	✗	✓
Additional Illustrations	✗	✓
Additional Blueprints	✗	✓
Tools List	✗	✓
Fastening Elements List	✗	✓
Technical Support	✗	✓

[TRY PREMIUM](#)



For more great **HOW-TO** plans please visit: <https://easycoops.com/>

Copyright

The text and illustrations that appear here are the exclusive property of shedplans.org and are protected by federal copyright laws. The duplication, sale or distribution of any portion of these plans without prior written consent from the original designer will be subject to the appropriate penalties for copyright infringement. Sharing this plan on the web is only permitted with an indicated original source: <https://easycoops.com/>